

# User Manual for TeraRanger Evo Swipe Plus (Touchless User Interface)



## Table of contents:

<b>Introduction</b>	<b>4</b>
About the TeraRanger Evo Swipe Plus	4
Technical Specifications	5
Performance Table	6
Communication interfaces	6
<b>Mechanical Integration</b>	<b>7</b>
Modular design (clip-on, clip-off)	7
Mechanical design and mounting	7
Mounting solutions	9
<b>USB Backboard Use</b>	<b>10</b>
LED Indication	10
Normal operation	10
Error messages and troubleshooting	10
Connecting the TeraRanger Evo to a Host Computer	11
Windows OS	11
<b>I2C/UART Backboard Use</b>	<b>14</b>
I2C/UART pinout	14
LED Indicators	15
Normal operation	15
Troubleshooting	15
Electrical characteristics	16
<b>USB/UART Normal Operation</b>	<b>16</b>
Operating Modes of the TeraRanger Evo Swipe Plus sensor	16
Bidirectional People Traffic Detection Mode	16
Presence Detection Mode	17
Engagement Trigger Mode	17
Gesture Recognition Mode	18
Swipe Mode	18
Validation Mode	19
Installation of Graphical User Interface Package	19
Linux and Raspberry Pi	19
Windows	19
Graphical User Interface (GUI)	20
Bidirectional People Traffic Detection Mode	21
Presence Detection Mode	21

Engagement Trigger Mode	22
Gesture Recognition Mode	22
Swipe Mode (Last gesture)	22
Validation Mode	22
Button to Reset Counters	22
List of sensor commands available via USB/UART	23
Details of the sensor output values	24
Output in Bidirectional People Traffic Detection Mode	24
Presence Detection Mode	25
Engagement Trigger Mode	25
Gesture Recognition Mode	26
<b>General Remarks</b>	<b>29</b>

## 1. Introduction

Evo Swipe Plus provides four complimentary modes in one small sensor module that is discreet and easy to integrate. The sensor will detect the presence of people and their proximity to the sensor, it will understand which direction people are moving in and switch to a touchless gesture recognition mode for people to interact with information panels, kiosks and other devices. Its touchless gesture recognition features offer convenience for users and companies by reducing the risk of virus transmission and the need for constant disinfection of user interfaces.

### 1.1. About the TeraRanger Evo Swipe Plus

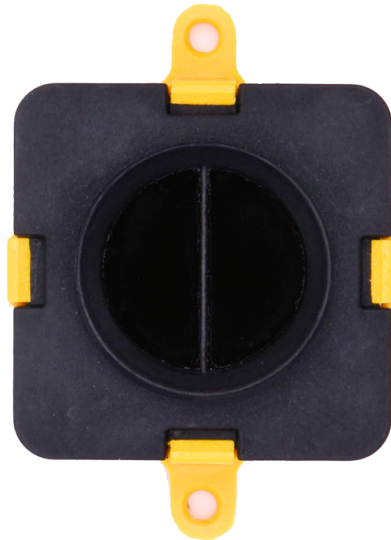

Figure 1. TeraRanger Evo Swipe Plus sensor, top view

The Evo Swipe Plus sensor has no open electronics and provides an ABS protected enclosure, resulting in a dust-proof and robust operation.

## 1.2. Technical Specifications

Table 1 - Technical specifications of TeraRanger Evo Swipe Plus

Product code	TR-EVO-SWP-PL-USB TR-EVO-SWP-PL-UART
<b>Performance</b>	<b>TeraRanger Evo Swipe Plus USB   UART</b>
Detection Principle	Infrared Time-of-Flight
Light Source Wavelength	940 nm
Use Environment	Indoor
Field of View	27°
Operation Modes	Presence Detection (PD) Bidirectional People Traffic Detection (BPTD) Engagement Trigger (ET) Gesture Recognition (GR)*
<b>Electronics</b>	
Supply Voltage	5V DC +/-5%
Current Consumption Average	50 mA
Initialization Time	< 1 s
<b>Communication</b>	
Serial Interface	USB 2.0 Micro-B UART, +3.3V level, 115200,8,1, None
Visual Notification	3 x LEDs (built-in backboards)
<b>Mechanical data</b>	
Dimensions	42 x 30 x 13 mm (incl. backboard)
Weight	9 g (incl. backboard)
Operating Temperature	-20° C to 75° C
Housing Material	ABS
Mounting Style	2 holes for M2 screws
Type of Connection	USB Backboard: USB 2.0 Micro-B I2C/UART Backboard: DF13-7p connector

## Conformity

Reference Standard CE, RoHS

\*For optimal performance the users' body should be more than 0.5 m from the sensor, with their hand swiping in the 0.1 m to 0.5 m range of the sensor.

### 1.2.1. Performance Table

Table 2 - performance table of the evo swipe plus

Mode	Detection	Output
<b>Bidirectional People Traffic Detection (BPTD)</b>	~ 0.3 m to 1.7 m ~25 Hz	<b>X:</b> People inside <b>Y:</b> People IN, <b>Z:</b> People OUT
<b>Presence Detection (PD)</b>	~ 0.2 m to 3 m ~20 Hz	<b>String:</b> "Presence" or "Person moved away" <b>X</b> : Presence count
<b>Engagement Trigger (ET)</b>	~ 0.5 m to 1.5 m PD~20 Hz BPTD~25 Hz	<b>Change Mode:</b> - BPTD or PD Modes to GR Mode - GR Mode to BPTD or PD Modes - <b>String:</b> "Engagement" or "Disengagement"
<b>Gesture Recognition (GR)</b>	<b>Swipe:</b> ~ 0.1 m to 0.5 m ~25 Hz <b>Validation:</b> ~ 0.01 m to 0.15 m ~25 Hz	<b>Swipe:</b> - <b>String:</b> "Left" or "Right" <b>Validation:</b> - <b>String:</b> "Validation"

### 1.2.2. Communication interfaces

Table 3 - Communication interfaces for the evo swipe plus

Evo Swipe Plus	Communication Interfaces
USB	•
UART	•

## 2. Mechanical Integration

### 2.1. Modular design (clip-on, clip-off)

The mechanical design of the main sensor module (black) allows easy assembly to its backboard (yellow) using a simple 'clip-on' technique. When clipping the two together, please ensure there is no visible gap between the black and yellow parts.

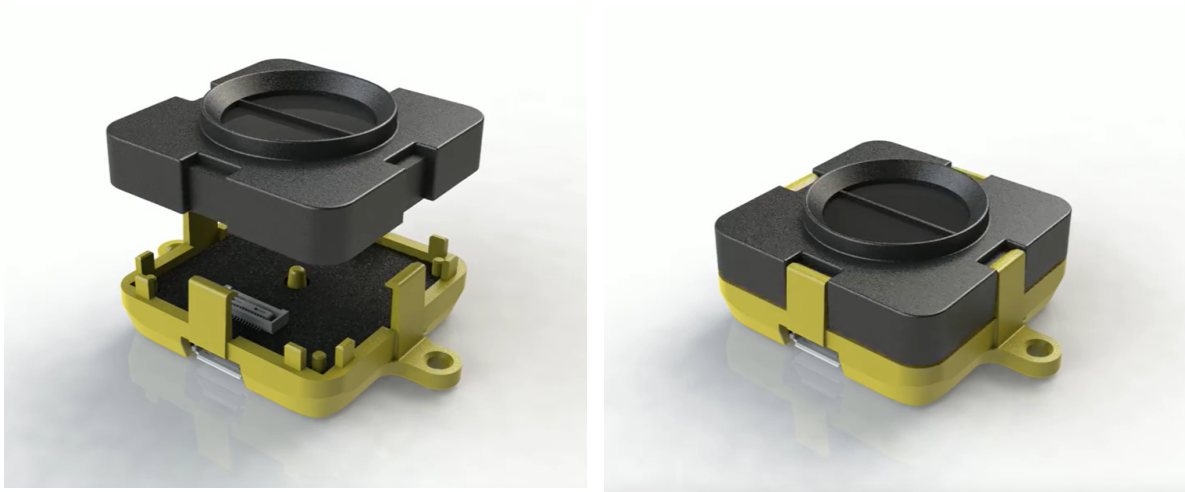

Figure 2 - Modular design of the TeraRanger Evo Swipe Plus sensor

### 2.2. Mechanical design and mounting

The TeraRanger Evo Swipe Plus sensor offers an ABS housing (both: sensor and backboard), with an option to mount the sensor using two holes compatible with M2 screws. Figure 3 illustrates the external dimensions of the TeraRanger Evo Swipe Plus sensor.

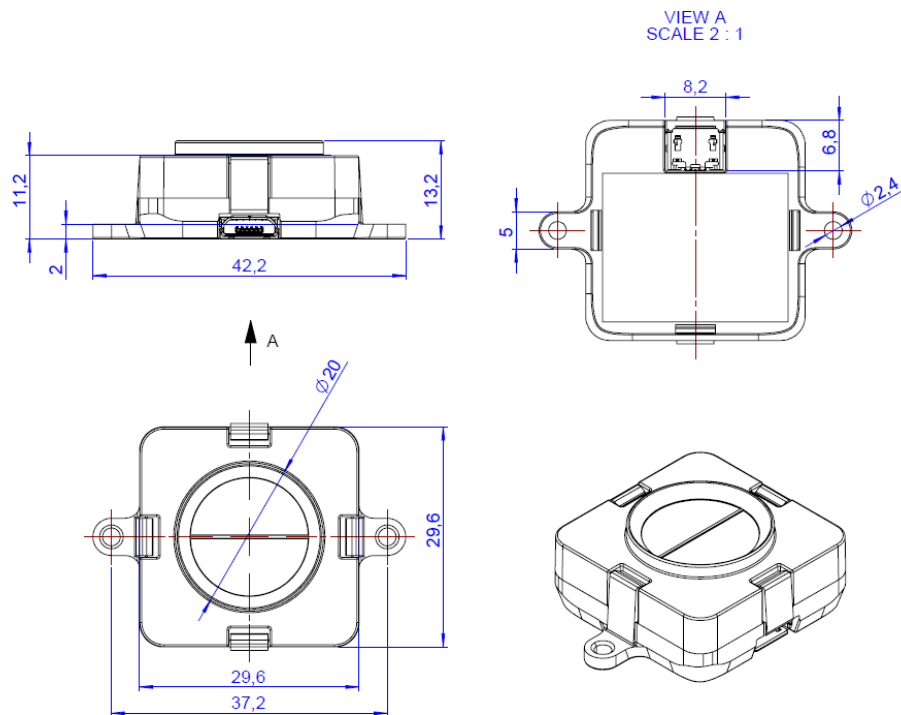

Figure 3 - TeraRanger Evo Swipe Plus external dimensions, USB backboard

The USB Backboard includes two holes for mounting the sensor using standard M2 screws. The following methods can be used to mount the TeraRanger Evo Swipe Plus sensor:

- 1- Front-panel mount using the M2 screws
- 2- Back-panel mount using the 2mm ledge on the front side of the sensor

Figure 4 illustrates the two different mount methods. The first solution allows for easy surface attachment and rapid evaluation of the sensor. The second provides a more discreet installation and supports design-in projects by installing the sensor behind a surface (e.g panel), ideally with 2mm thickness.





Figure 4 - Front-panel mounting (left image); back-panel mounting (right images)

## 2.3. Mounting solutions

When choosing a place for mounting the TeraRanger Evo Swipe Plus, please consider the following recommendations:

- Mounting close to sources of heat or strong electromagnetic fields can decrease sensor performance
- Do not mount anything directly in front of the sensor or in a cone of approximately  $\pm 35^\circ$  around the central optical axis of the sensor
- It is advisable to avoid having other sources of Continuous Wave or modulated Infrared light sources near the sensor
- Please consider that dust, dirt and condensation can affect sensor performance
- It is not advised to add an additional cover in front of the sensor



*During assembly and integration, please observe all common ESD precautions. All optical surfaces (sensor front) should be kept clean and free from contact with chemicals.*

## 3. USB Backboard Use

### 3.1. LED Indication

#### 3.1.1. Normal operation

Three LED indicators are present on the USB backboard, and are visible through the back of the yellow plastic case.

Table 4 - LED indicators of the USB backboard

LED designator	Description
<b>PWR (ORANGE)</b>	The Power LED is ON whenever the sensor is powered
<b>RED</b>	Flashes briefly on startup to indicate proper initialization; then switches off
<b>GREEN</b>	Blinks 8 times at power up GREEN LED blinks every 5 seconds when the sensor is streaming data

#### 3.1.2. Error messages and troubleshooting

Table 5 - USB backboard LEDs troubleshooting

LED designator	Sequence	Signification	Corrective actions
<b>RED</b>	Continuous blinking	Sensor has detected a fault and has stopped functioning	Check that the sensor is properly connected to the backboard, then restart the sensor
<b>RED / GREEN</b>	Both LEDs blinking continuously	Sensor has detected a fault in the sensor initialization process	Check USB output for details of the error  Verify that the sensor is properly connected and re-power the unit

## 3.2. Connecting the TeraRanger Evo to a Host Computer

### 3.2.1. Windows OS

In Windows it is possible to use any terminal emulation software for data display. Terabee works with and suggests using HTerm software. Please follow the provided link to download the software file (<http://www.der-hammer.info/terminal/>), and select the appropriate file for your platform.

*Tested with version 0.8.4 on Linux x64 and Windows 10 x64 platforms.*

When using Windows, extract the downloaded *zip* file to the selected folder, open it and double click on the “HTerm.exe” file.

When using Linux, extract the downloaded *tgz* file to the selected folder, make sure that you have execution permission for the file “hterm” (command: `chmod u+x hterm`), double click on the “hterm” file or run it from terminal while in its directory: `./hterm`.



*On Linux, consider removing the modemmanager package if you are sure that it is not required by your system setup. This will shorten the initialization time of serial devices in the Linux system:*

```
sudo apt purge modemmanager
```

Connect the TeraRanger Evo Swipe Plus to a computer and select the corresponding USB port (click “R” button to refresh the port list). Please configure the software with the following parameters:

**Baud rate** : 115200 bit/s  
**Data bits** : 8  
**Stop bit** : 1  
**Parity bit** : None

For easier data reading, select the “LF” option from the “Newline at” drop-down field. See Figure 5 below for visual instructions.

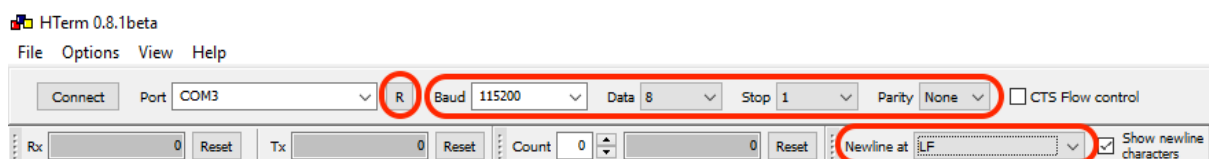

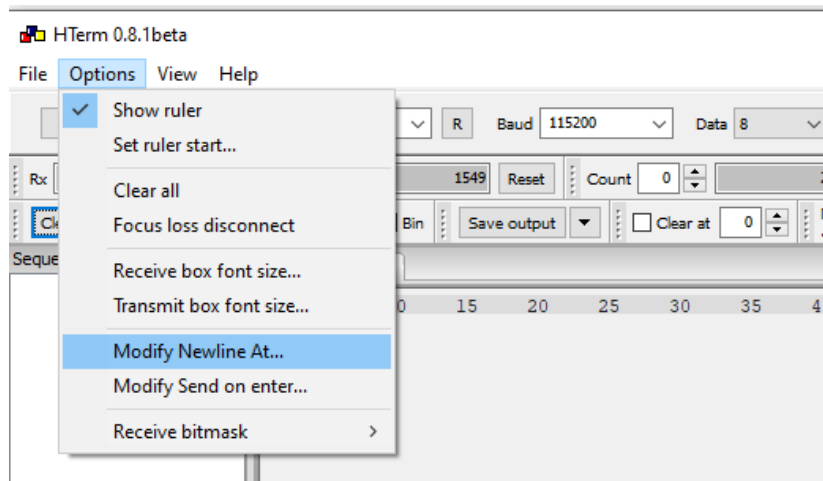

Click on LF, and in the line-end marker select the header of the operating mode for easier data reading.

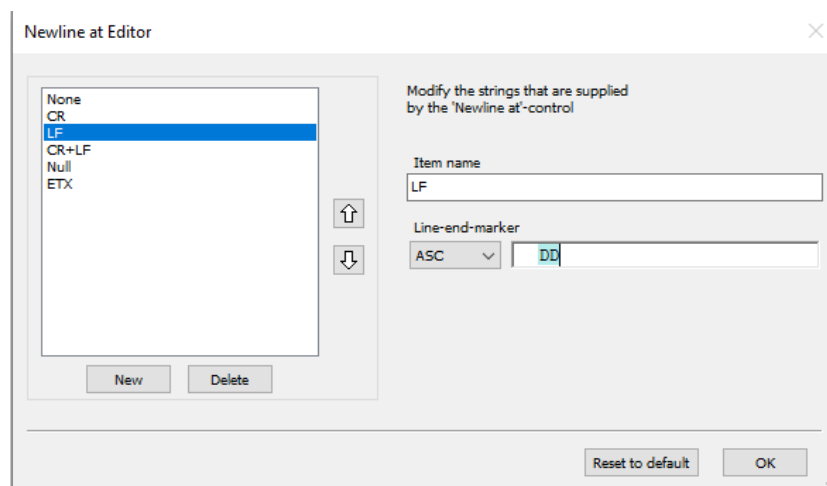

Figure 5 - HTerm parameters for TeraRanger Evo Swipe Plus

Once the USB port is selected and the parameters correctly set, click on the **“Connect”** button.

The TeraRanger Evo Swipe Plus data will now appear in the “Received data” box depending on the current working mode (see Figure 6).

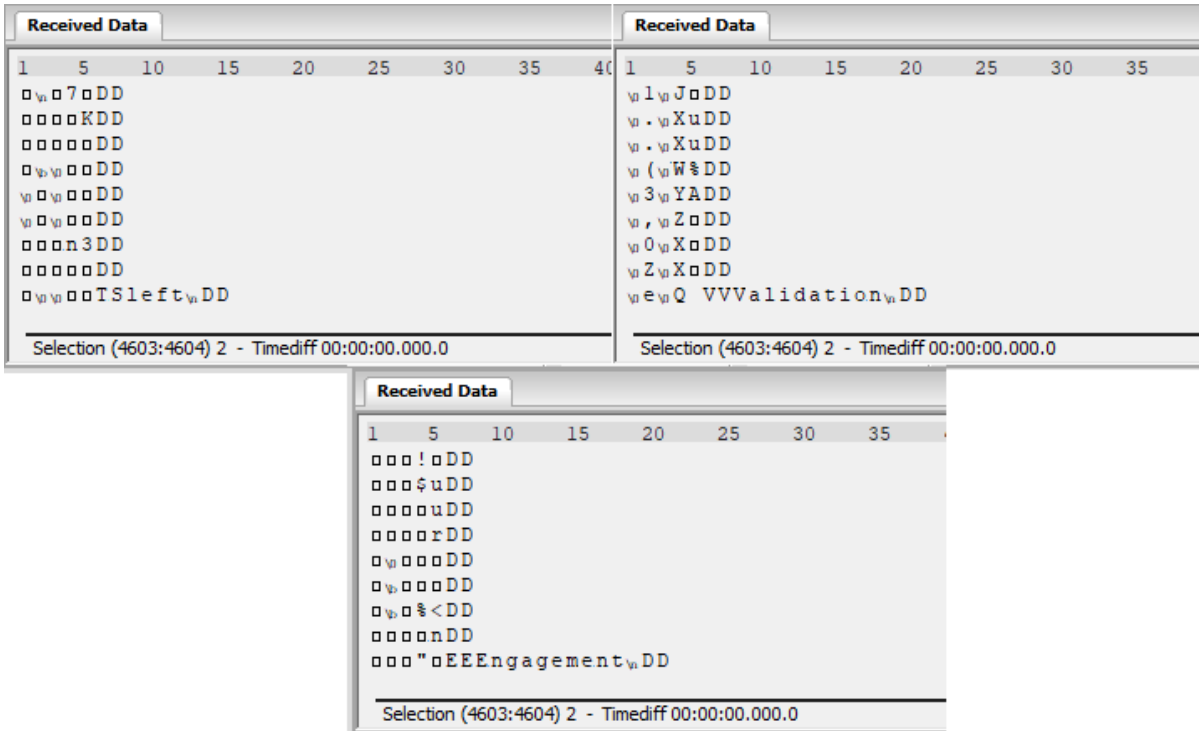

Figure 6 - Example of Data stream on HTerm software

## 4. I2C/UART Backboard Use

The TeraRanger Evo Swipe Plus sensor can output data through a UART interface using an I2C/UART backboard.

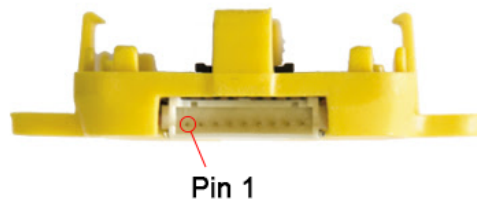

Figure 8 - I2C/UART backboard front view

### 4.1. I2C/UART pinout

The I2C/UART backboard uses a single 9 pin Hirose DF13 connector for interfacing to the host system. The mating connector is a Hirose DF13-9S-1.25C with crimping contacts DF13-2630SCF (tin) or DF13-2630SCFA (gold). Please consider the mechanical stability of the mated connectors and avoid any kind of excess force on the connector (during installation and once integrated) and follow the recommendations in the Hirose DF13 series datasheet (available here:

<https://www.hirose.com/product/en/products/DF13>) to ensure a reliable connection.

Table 6 - Pinout and description (According to DF13 datasheet)

Pin	Designator	Description
1	Tx	UART transmit output. 3.3V logic
2	Rx	UART receive input. 3.3V logic
3	GND	Power supply and interface ground
4	SDA	I2C serial data line. 3.3V logic
5	SCL	I2C serial clock line. 3.3V logic
6	rfu	RESERVED FOR FUTURE USE
7	5V	+5V supply input
8	GND	Power supply and interface ground
9	rfu	RESERVED FOR FUTURE USE

## 4.2. LED Indicators

### 4.2.1. Normal operation

The I2C/UART Backboard has three built-in LEDs behind the yellow case to visualize feedback of the sensor status. Table 7 lists the functionality of each LED of the I2C/UART backboard.

Table 7 - LED indicators of the I2C/UART backboard

LED	Description
<b>PWR (orange)</b>	Power indicator, constantly ON when 5V is supplied
<b>Rx (red) Tx (green)</b>	I2C/UART receive and transmit indicators. Single blink for each data received or sent

### 4.2.2. Troubleshooting

Table 8 - I2C/UART backboard LEDs troubleshooting

LED designator	Sequence	Signification	Corrective actions
<b>RED</b>	Continuous blinking	Sensor has detected a fault and has stopped functioning	Check that the sensor is properly connected to the backboard, then restart the sensor
<b>RED / GREEN</b>	Both LEDs blinking continuously	Sensor has detected a fault in the sensor initialization process	Check I2C/UART output for details of the error  Verify that the sensor is properly connected and restart

### 4.3. Electrical characteristics

Table 9 - TeraRanger Evo Swipe Plus power consumption

Parameter	Minimum	Maximum	Average
<b>Power supply</b>			
Voltage input (V)	4.5V	5.5V	5V
Current consumption (mA)	25mA	75mA	50mA
<b>Interface logic levels</b> (referenced to +3V3)			
LOW	-	1	-
HIGH	2.3	-	-

## 5. USB/UART Normal Operation

### 5.1. Operating Modes of the TeraRanger Evo Swipe Plus sensor

The TeraRanger Evo Swipe Plus features 4 modes:

- Bidirectional PeopleTraffic Detection Mode
- Presence Detection Mode
- Engagement Trigger Mode
- Gesture Recognition Mode (includes Swipe and Validation sub-modes)

#### 5.1.1. Bidirectional People Traffic Detection Mode

In Bidirectional People Traffic Detection Mode, the sensor counts people passing in front of the TeraRanger Evo Swipe Plus.

The output of the sensor is:

- A meter counting the number of people passing by, from left to right
- A meter counting the number of people passing by, from right to left

The sensor should be installed with the USB/UART Connector on the right side as shown in figure 9.



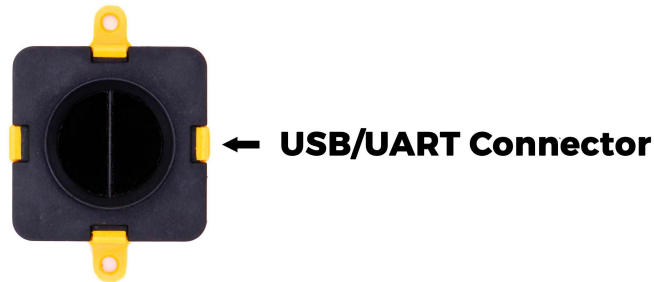

Figure 9: Sensor orientation for People Counting Mode

The detection range of this mode can be adjusted from a minimum of 0.3 m to a maximum of 1.7 m. To detect a person passing the set detection range has to be breached.

### 5.1.2. Presence Detection Mode

In Presence Detection Mode, the sensor counts people passing by in front of the Evo Swipe Plus, regardless of their direction. A presence is detected when a person is standing at a set range for a set time. The sensor registers that a person has left when their distance from the sensor is equal to or above the maximum range for the specified amount of time

The output of the sensor is:

- A character string reporting that a person enters or leaves the field of detection of the sensor
- A meter counting the number of people detected

The time threshold of this detection mode can be adjusted from a minimum of 0,1 second to a maximum of 3 seconds.

The detection range of this mode can be adjusted from a minimum of 0.2 m to a maximum of 3.0 m, the default range being 2.5 m.

**Note: The “Bidirectional People Traffic Detection Mode” and “Presence Detection Mode” are exclusive.** Please refer to [section 5.3 “Graphical User Interface \(GUI\)”](#) to read how to switch between the 2 modes.

### 5.1.3. Engagement Trigger Mode

In Engagement Trigger Mode, the sensor raises a flag when a person is identified as engaged, meaning standing at a set range for a set time. When this situation occurs, the

sensor switches from Presence Detection or Bidirectional People Traffic Detection Mode to Gesture Recognition Mode - read details in the next section.

When the “engaged” person is leaving, the sensor detects the change and switches back from Gesture Recognition Mode to Presence Detection Mode or Bidirectional People Traffic Detection Mode.

When changing its state, the sensor outputs a character string corresponding to Engagement or Disengagement.

The time threshold of the engagement trigger mode can be adjusted from a minimum of 1 second to a maximum of 10 seconds. The time of disengagement can vary from 1 to 10 seconds.

By default, the set engagement range is 1 m, and can be adjusted from a minimum of 0.5 m to a maximum of 1.5 m.

## **5.1.4. Gesture Recognition Mode**

Gesture Recognition Mode comprises 2 sub-modes operating at the same time: Swipe Mode and Validation Mode.

### **5.1.4.1. Swipe Mode**

Swipe Mode activates when a person is “engaged” - refer to above section 5.1.3 Engagement Trigger Mode.

Swipe Mode: the sensor detects Left to Right or Right to Left hand gestures performed in front of the sensor. The connector of the USB/UART backboard should be placed on the right, Figure 10 illustrates the correct orientation of the TeraRanger Evo Swipe Plus.

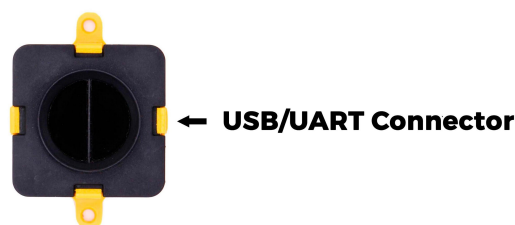

Figure 10: Sensor orientation for Swipe Mode

- When a person performs a Right to Left gesture, the sensors outputs a character string “Left”

- When a person performs a Left to Right gesture, the sensor outputs a character string "Right"

The default working range is from 0.2 m to 0.4 m, and can be adjusted from a minimum of 0.1 m to a maximum of 0.5 m.



*The user's body should be more than 0.5 m away from the sensor, with their hand swiping in the 0.1 m to 0.5 m range of the sensor, to avoid negatively affecting the sensor's behavior and to remain out of the sensor's field of view.*

#### **Notes:**

1. A minimum of 0.1 m is required between minimum and maximum working ranges
2. For an optimal use, a minimum of 0.25 m is required for the maximum working range of Swipe Mode and the minimum working range of Engagement Trigger Mode.

#### **5.1.4.2. Validation Mode**

Through validation mode, the sensor detects a validation event when a person places his/her hand below a set distance in front of the sensor for a set duration (a few seconds). When a validation is acknowledged, the sensor outputs a character string "Validation".

The default working range is 0.15 m, and can be adjusted from a 0.01 m to 0.15 m.

**Note:** For optimal use, a minimum of 0.05 m is required between the validation working range and the minimum working range of Swipe Mode.

## **5.2. Installation of Graphical User Interface Package**

### **5.2.1. Linux and Raspberry Pi**

Instructions:

- Open a terminal in the evo\_swipe\_plus folder (evo\_swipe\_plus-arm for Raspberry Pi and other Armv7l)
- Type: `Pip install -r requirements.txt`
- Launch: main.py by typing: `python3 main.py`

### **5.2.2. Windows**

Instructions:

- Double click on EvoSwipePlus\_1.2 to launch executable and Install.

- To launch the GUI double click on the icon “EvoSwipePlus” on the Desktop
- To launch with terminal information, right click on the icon and choose “Open file location”.
- Open a cmd terminal there and type the command: “`cd ..`” and then `Python\python.exe pkgs\main.py`

## 5.3. Graphical User Interface (GUI)

The GUI allows you to:

- Set up the parameters for the different modes of Evo Swipe Plus sensor
  - Bidirectional People Traffic Count
  - Presence Count
  - Engagement Trigger
  - Swipe (Swipe: Last Gesture)
  - Validation (Validation Status)
- Test in near real-time the behavior of Evo Swipe Plus sensor and report the status and counts related to its different modes



**Important:**

*Once you update the parameters through the GUI (e.g. Presence Detection Mode or thresholds with the sliders), **these parameters are automatically pushed to the TeraRanger Evo Swipe Plus sensor***

You can read the details of the GUI on Figure 11 below.

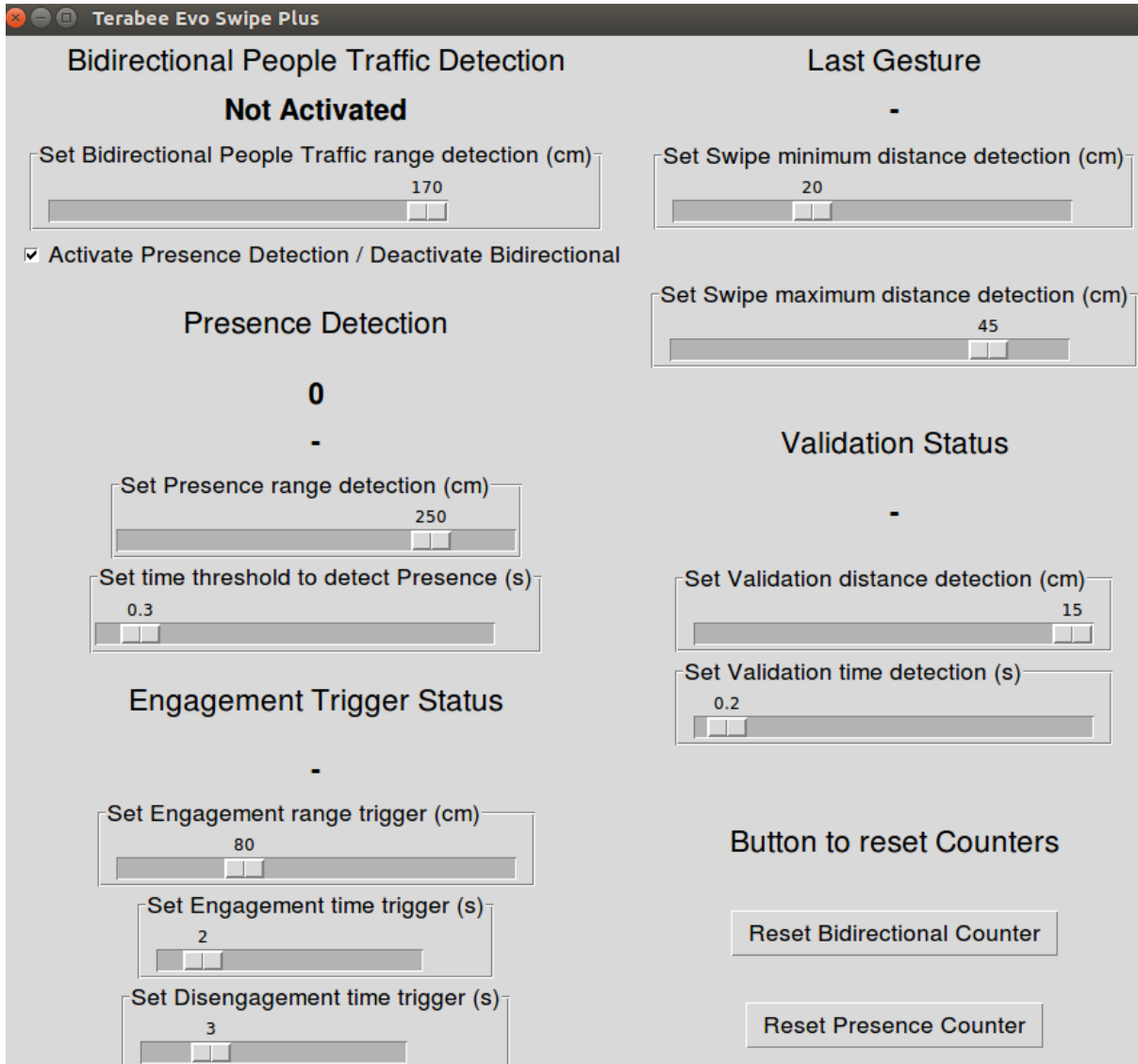

Figure 11: GUI in standard mode

### 5.3.1. Bidirectional People Traffic Detection Mode

Bidirectional People Traffic Detection Mode is activated by default. The three numbers below the title correspond to three meters:

- Meter 1 displays the difference between the 2<sup>nd</sup> and the 3<sup>rd</sup> meter.
- Meter 2 counts people passing by from left to right,
- Meter 3 counts people passing by from right to left

### **5.3.2. Presence Detection Mode**

By default, Presence Detection is "Not activated". Presence Detection can be activated by ticking the checkbox "Activate Presence Detection". Once activated:

- The status notification switches between "Presence" and "Person moved away"
- A meter counts the number of people passing by
- The first slider sets the Presence detection range in cm.
- The second slider sets a Presence detection threshold in seconds, after which a person standing before the sensor is detected as present

### **5.3.3. Engagement Trigger Mode**

- The status of Engagement Trigger mode is either "Engagement" or "Disengagement"
- The first slider sets the engagement Trigger range in cm.
- The second slider sets the Engagement time detection in seconds, after which a person standing in front of the sensor is detected as engaged
- The third slider sets the Disengagement time in seconds, after which a person who has moved away from the sensor is detected as disengaged

### **5.3.4. Gesture Recognition Mode**

#### **5.3.4.1. Swipe Mode (Last gesture)**

- The "Last Gesture" status can be either "Right" or "Left".
- The first slider sets the minimum range in cm to detect swipe gestures
- The second slider allows you to set the maximum threshold to detect gestures

#### **5.3.4.2. Validation Mode**

- When a validation gesture is detected, the status displays "Validation"
- The first slider sets a range in cm, under which a validation gesture is detected
- The second slider sets a minimum time threshold in seconds, after which a hand gesture is detected as a validation

#### **5.3.4.3. Button to Reset Counters**

- Reset Bidirectional Counter: reset the counts to: 0 0 0
- Reset Presence Counter: reset the count to: 0

## 5.4. List of sensor commands available via USB/UART

The commands listed below can be used to push default parameters to an Evo Swipe sensor via a command line within an HTerm window, or through a Python script for example.

Table 10 - List of commands for TeraRanger Evo swipe plus

Command (HEX)	CRC-8	Command description
00 21 07	AE	MODE PRESENCE DETECTION (PD)
00 21 0A	8D	MODE BIDIRECTIONAL PEOPLE TRAFFIC DETECTION (BPTD)
00 55 03 MM NN SS TT	Dependent on the value of: MM,NN, SS,TT <sup>3</sup>	CHANGE BPTD THRESHOLDS SETTING: MMNN <= 1700 (millimeters) 300 <= SSTT (millimeters) (SSTT + 200) <= MMNN (millimeters)
00 55 07 YY ZZ UU VV	Dependent on the value of: YY,ZZ,UU, VV <sup>3</sup>	CHANGE PD SETTING: Thresholds 200 <= YYZZ <= 3000 (millimeters) Time 100 <= UUVV <= 3000 (millisecond)
00 55 05 II GG KK LL	Dependent on the value of: II,GG,KK, LL <sup>3</sup>	CHANGE ENGAGEMENT TRIGGER SETTING: (EEFF + 250) <= IIGG <= 1500 (millimeters) Engagement time 1 <= KK <= 10 (second) Disengagement time 1 <= LL <= 10 (second)
00 55 04 EE FF JJ HH	Dependent on the value of: EE,FF,JJ, HH <sup>3</sup>	CHANGE GR SWIPE THRESHOLDS SETTING: EEFF <= 500 (millimeters) 100 <= JJHH (millimeters) (JJHH + 100) <= EEFF (millimeters)
00 55 06 OO PP QQ RR	Dependent on the value of: OO,PP,QQ ,RR <sup>3</sup>	CHANGE GR VALIDATION SETTING: Validation Thresholds OOPP <= (JJHH + 50) (millimeters) OOPP <=150 Validation Time 1000 <= QQRR <= 5000 (millisecond)
00 55 08 00 00 00 00	7C	RESET BIDIRECTIONAL PEOPLE TRAFFIC DETECTION COUNTING
00 55 09 00 00 00 00	1E	RESET PRESENCE DETECTION COUNTING
00 61 01	E7	OUTPUT SETTING:

---

## BINARY OUTPUT PARAMETERS SETTINGS VALUES

---

00 61 02                      EE              OUTPUT SETTING:  
 TEXT OUTPUT PARAMETERS SETTINGS VALUES

---

<sup>3</sup> Where MM NN SS TT is max and min of BPTD thresholds in hexadecimal format. (order is very important)  
<sup>3</sup> Where EE FF JJ HH is max and min of GR SWIPE thresholds in hexadecimal format. (order is very important)  
<sup>3</sup> Where II GG KK LL is the Engagement Trigger data “ thresholds and time” in hexadecimal format. (order is very important)  
<sup>3</sup> Where OO PP QQ RR is the GR VALIDATION data “ thresholds and time” in hexadecimal format. (order is very important)  
<sup>3</sup> Where YY ZZ UU VV is the PD thresholds and time in hexadecimal format. (order is very important “MSB,LSB”)

Please refer to Section [Connecting the TeraRanger Evo to a Host Computer](#) for instructions on how to send commands to the TeraRanger Evo Swipe Plus sensor using a host computer and the HTerm emulation software.

 *Each command message frame must be transmitted in a continuous stream, ie. not byte by byte*

 *It is advised to maintain a time interval of a few microseconds between two messages for proper command registration*

## 5.5. Details of the sensor output values

### 5.5.1. Output in Bidirectional People Traffic Detection Mode

In Bidirectional People Traffic Detection Mode, the sensor counts people passing by in front of the Evo Swipe Plus

When streaming data using HTerm, the TeraRanger Evo Swipe Plus sensor goes on streaming frames that contain a header of “DD” followed by two distances. Each distance is represented by two bytes and one CRC byte.

“DD” 2 bytes	D1 2 bytes	D2 2 bytes	CRC 1 byte
-----------------	---------------	---------------	---------------

Once the sensor detects and validates the Bidirectional People Traffic, the sensor outputs the following frame that contains this additional information:

“PC” 2 bytes	Counter 4 bytes	Counter IN 2 bytes	Counter OUT 2 bytes	CRC 1 byte
-----------------	--------------------	-----------------------	------------------------	---------------



Where: "PC": frame header.

Counter = Counter IN - Counter OUT

Counter IN: number of people passing by from Left to Right

Counter OUT: number of people passing by from Right to Left

### 5.5.2. Presence Detection Mode

In Presence Detection Mode the sensor counts the presence of people in front of the TeraRanger Evo Swipe Plus

When streaming data using HTerm, the sensor goes on streaming frames that contain a header of "TT" followed by one distance represented by two bytes and one CRC byte.

"TT"	D1	CRC
2 bytes	2 bytes	1 byte

Once the sensor detects and validates a Presence Detection (e.g. "person present for more than x seconds"), the sensor outputs the following frame that contains this additional information:

"PP"	"Presence": 8 bytes "Person moved away": 17 bytes	"\n"	Presence Detection counter
2 bytes		1 byte	4 bytes

Where: "PP": frame header

String message: "Presence" or "Person moved away"

New line character: \n (10 decimal / 0x0A hex)

Presence Detection meter counting people detected as present

### 5.5.3. Engagement Trigger Mode

This mode provides users with specific data related to the engagement status, depending on the operating mode.

When streaming data using HTerm, the sensor continues sending distance frames - see above frames for each mode (BPTD and PD).

Once the sensor detects and validates an Engagement - meaning the detection of a person standing below a range of "x" meters for more than "y" seconds - or a Disengagement - meaning the person is no longer detected after "z" seconds - the sensor outputs the following frames that contain this additional information:

“EE” 2 bytes	“Engagement” :10 bytes “Disengagement” :13 bytes	“\n” 1 byte
-----------------	---	----------------

Where: “EE”: frame header  
String message: “Engagement” or “Disengagement”  
New line character: \n (10 decimal / 0x0A hex)

### 5.5.4. Gesture Recognition Mode

This mode provides users with specific data related to the hand gesture in a close range once the sensor has switched in Gesture Recognition Mode.

When streaming data using HTerm, the sensor streams a frame that contains a header of “DD” followed by two distances. Each distance is represented by two bytes and one CRC byte.

“DD” 2 bytes	D1 2 bytes	D2 2 bytes	CRC 1 byte
-----------------	---------------	---------------	---------------

Once the sensor detects and validates the hand gesture, the sensor outputs the following frame that contains the additional information:

- In the case of a swipe hand movement:

“TS” 2 bytes	“Right” : 5 bytes “Left” : 4 bytes	“\n” 1 byte
-----------------	---------------------------------------	----------------

Where: “TS”: frame header  
String message: “Right” or “Left”, depending on the swipe direction  
New line character: \n (10 decimal / 0x0A hex)

- In the case of a validation hand movement:

“VV” 2 bytes	“Validation” 10 bytes	“\n” 1 byte
-----------------	--------------------------	----------------

Where: “VV”: frame header  
String message: “Validation”  
New line character: \n (10 decimal / 0x0A hex)

## 5.5.5. *Reset counters*

This command will reset the counters for both presence detection and bidirectional people traffic detection modes.

Once the sensor receives the reset command, the sensor outputs the following frames that contain this additional information:

### 5.5.5.1. BPTD “Bidirectional People Traffic Mode”

“PC” 2 bytes	Counter 4 bytes	Counter IN 2 bytes	Counter OUT 2 bytes	CRC 1 byte
-----------------	--------------------	-----------------------	------------------------	---------------

Where: “PC”: frame header

Counter = Counter IN - Counter OUT = **0**

Counter IN: number of people passing by from Left to Right = **0**

Counter OUT: number of people passing by from Right to Left = **0**

CRC Byte

### 5.5.5.2. PD Presence Detection Mode

“PP” 2 bytes	Presence Detection counter 4 bytes	CRC 1 byte
-----------------	---------------------------------------	---------------

Where: “PP”: frame header

Presence Detection meter counting people detected as present = **0**

CRC Byte

## 5.5.6. *Parameters Command*

### 5.5.6.1. *Binary Frame*

This command provides users with all parameter values in binary form and returns the following frames:

“BP”	BPTD max range thresholds (millimeters)
------	---

2 bytes	2 bytes
---------	---------

“PD” 2 bytes	PD max range thresholds (millimeters) 2 bytes	PD time thresholds (millisecond) 2 bytes
-----------------	--	---

“ET” 2 bytes	range trigger (millimeters) 2 bytes	engagement time (seconds) 1 byte	disengagement time (seconds) 1 byte
-----------------	---	--	---

“GR” 2 bytes	swipe minimum thresholds (millimeters) 2 bytes	swipe maximum thresholds (millimeters) 2 bytes	validation range thresholds (millimeters) 2 bytes	validation time thresholds (milliseconds) 2 bytes
-----------------	---	---	--	--

CRC 1 byte
---------------

### 5.5.6.2. Text Frame

This command provides users with all parameter values in text form and returns the following frames:

```
BPTD: max range thresholds: xxxx [mm]<\n> PD: max range thresholds: xxxx [mm]
time thresholds: x.xxxxxx [s]<\n>ET: range trigger: xxxx [mm] engagement time: x [s]
disengagement time: x [s]<\n>GR: swipe minimum thresholds: xxxx [mm] swipe
maximum thresholds: xxxx [mm] validation range thresholds: xxxx [mm] validation time
thresholds: x.xxxxxx [s]<\n>
```

## 6. General Remarks

- If the sensor is disconnected/powered down, the BPTD or PD counters are automatically reset.
- The parameter sliders present in the GUI are connected to each other. For instance, if you move the maximum range value for the Swipe Mode too close (<25 cm) to the minimum range threshold of the Engagement Trigger Mode, then this Engagement threshold will automatically increase to keep the minimum range interval required.
- Once a validation gesture has been detected, a left/right movement may be detected immediately after, if the person's hand is properly aligned with the sensor. In this case, we suggest:
  - Increase the gap between the respective thresholds of the Validation and Swipe mode, in order to filter unwanted Swipe detection.
  - Set a timer of 0.5 seconds after a Validation event, in order to not acknowledge the following movement (hand exiting a validation status).